

# IR RemoteBlaster

## Quick Installation Guide

### for the WinTV v7 application

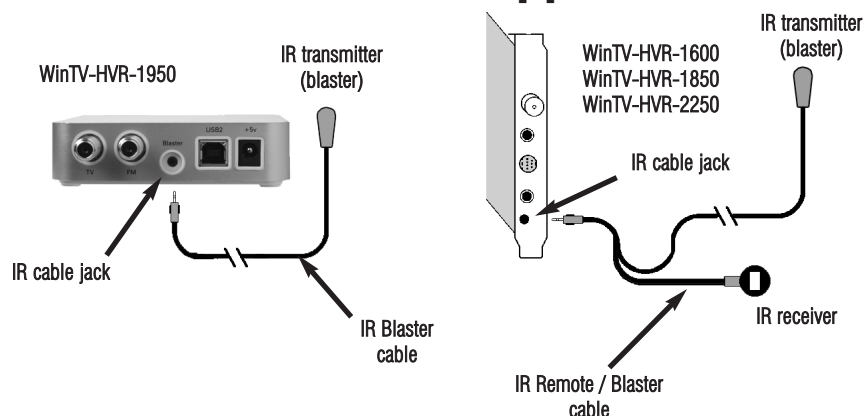

The **IR RemoteBlaster** lets the Hauppauge WinTV 7 application change the channel on a satellite or cable TV set top box by transmitting 'channel change' commands to the box via an Infra Red (IR) transmitter. The IR blaster duplicates the number keys which would normally be transmitted by your set top box remote control.

### Installing the IR blaster hardware

The **IR RemoteBlaster for WinTV** consists of four components:

1. The **Hauppauge remote control**, which sends infrared signals to the IR Receiver.
2. **IR RemoteBlaster cable**, which is plugged into the WinTV card. This cable has an **IR cable jack** and two ends: a **IR receiver** and an **IR transmitter**. The **IR transmitter** has a thin wire and is at the end of the longer "leg" of the cable.
3. **IR32 application**, a program which runs in the Windows device tray and interprets signals received by the IR receiver.
4. **IR Blaster Config program**, for configuring the IR transmitter.

**Note:** if you are **NOT** using a set top box, you do not need to use the **IR transmitter (blaster)** end of the **IR Remote Blaster cable**.

**Note:** you can only use the **Hauppauge remote control** or a certified **Windows Media Center remote control with IR RemoteBlaster**. The **IR Receiver** does not respond to remote control transmitters from other devices like a **TV set or VCR**.

**Note:** Before installing the **IR Remote Blaster cable**, install the **WinTV board plus driver and application software from the WinTV Installation CD ROM**. Make sure that the **WinTV application works properly when using your mouse or keyboard**.

During the installation of the WinTV software from the **WinTV Installation CD-ROM**, the

**Hauppauge WinTV IR and IR Blaster Applications** will be automatically installed. You will be asked during the IR software installation to acknowledge a software license.

You can manually install the **Hauppauge WinTV IR and IR Blaster applications** from the Installation CD by running **irblast.exe** from the IR32 directory of your Hauppauge Installation CD-ROM.

When Windows is booted, the **IR32 application** is automatically run and you will notice a small IR icon in your system device tray. You can reset the IR application by running **RestartIR** from the Hauppauge WinTV folder.

### Step 1: Plug the IR RemoteBlaster cable into your WinTV product

Plug the **IR RemoteBlaster cable** into the **IR receiver jack** on your WinTV product.

**Note:** be sure the **IR Cable jack** is well seated in the **WinTV board**. You might need to **wiggle the WinTV board and/or the IR RemoteBlaster cable** to get it firmly seated. If it is not well seated, the **WinTV application** will not respond to commands from the **Hauppauge remote control**.

### Step 2: Position the IR receiver

Place the **IR Receiver** from the **IR RemoteBlaster cable** so that the light beam from the **Hauppauge remote control** can hit it. On the WinTV-HVR-1950, the IR receiver is built into the front of the case.

### Step 3: Check the function of Hauppauge Remote for WinTV

Point the Hauppauge remote at the IR receiver and click the **Go button**. You should see the **WinTV open**.

**Note:** If you click the **Go button** and the **WinTV** does not open, wiggle the **WinTV board** and/or the **IR RemoteBlaster jack** to get the **jack** firmly seated. If it is not well seated, the **WinTV application** will not respond to commands from the **Hauppauge remote control**. Also, make sure you have installed batteries in the **Hauppauge remote**.

### Step 4: Position the IR transmitter (blaster) at your set top box

**Note:** The next steps (4 through 7) are optional and only required if you want **WinTV** to control the **TV channels on a satellite or cable TV set top box through WinTV's IR transmitter (blaster)**.

Attach the end of the **IR transmitter** over the **remote sensor** on the set top box to be controlled. **Placement of the IR transmitter is important!** The IR transmitter only works over a 2 inch distance, so you need to make sure it is placed over the remote sensor in your set top box. Some set top boxes have the position of the remote receiver indicated on the plastic front of the set top box. With others, you might need to look carefully at the set top box for what looks like a round or square area underneath the plastic front panel.

There is double sided tape on the back of the IR transmitter to hold it in place over the remote sensor in your set top box.

### Step 5. Connect the set top box's audio/video outputs to the WinTV

This is the same as connecting a set top box to a TV set: chose either composite video, S-Video or TV tuner as the way to connect from the set top box to WinTV. Some set top boxes send video via channel 3 or 4, others have composite or S-Video outputs. Chose one method and make the necessary audio/video connections from your set top box to WinTV.

### Step 6: Configure the video source in the WinTV v7 application

After you make the video connection from your set top box to WinTV in step 5, you need to tell WinTV where the audio/video from your set top box is coming from. Many set top boxes use a channel 3 or channel 4 output via an RF output connector. Other boxes use S-Video or Composite video for output. In either case, you need to tell WinTV where the video will be coming from.

To configure blaster channels, in **WinTV v7** click on the **Settings button** and go to **Devices tab**. Highlight your Hauppauge TV tuner device and click **Tuner setup**.

You will see the **Device Setup Wizard** with your WinTV device specified.

Put a check in **Analog TV via set top box**.

Click **Next**.

Then choose the connection you are using: **S-video, composite** or **tuner** (if tuner, choose the channel the box is tuned to).

Check the box **Use IR Blaster to control STB**.

Click **Next**.

Now, you need to add your set top box TV channels to the WinTV channel list.

If you are in the U.S., there is a Internet based list of channels which is available in some areas. To use the Internet list of channels, see the section entitled "**Automatic mapping of your set top box channel numbers to the IR blaster (U.S. only)**".

If you cannot use the Internet list of channels, you need to enter each channel you want the IR blaster to tune to. To manually add these channels, enter the **TV channel number** and **name** (optional) and click **Add**. You must repeat this process for

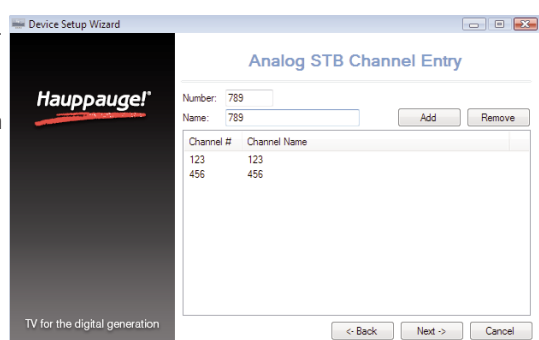
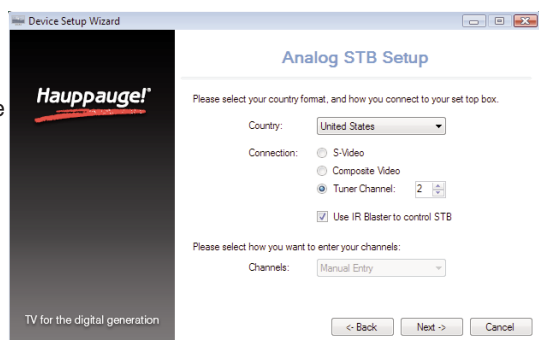

all TV channels you wish to receive through your set top box.

When finished, click **Next**. You will now have a list of set top box channels WinTV can automatically tune to. When you want WinTV v7 to tune to a channel which is in the Channel list, your Hauppauge TV tuner will send a sequence of IR 'blinks' to your set top box, causing it to change channels.

### Configure the IR transmitter to control your set top box

If you are using a WinTV-HVR-1600 or the WinTV-HVR-1950, there is a list of set top boxes which the IR Blaster is pre-configured to control. See the section entitled "**Using the pre-configured list of set top boxes**".

If you are using the WinTV-HVR-1850 or the WinTV-HVR-2250, or you have a set top box which the Blaster Config program does not know about, you must use the **Learning Mode** for the IR Blaster. See the next section "**Learn mode: learning the remote control codes for your set top box**".

### Learn mode: learning the remote control codes for your set top box (WinTV-HVR-1600, WinTV-HVR-1850, WinTV-HVR-1950 and WinTV-HVR-2250)

The WinTV v7 application can "learn" new remote control codes for most cable TV and satellite TV set top boxes. To access the learn function, in the **Blaster Config** program click on **Advanced Config**. You will need to 'learn' the **0 through 9 keys**, plus **Power on** and **Enter**.

**Note:** You will need the remote control from your set top box to complete the configuration in this section.

**Note:** this procedure is only necessary if you are using WinTV v7. If you are using Windows Media Center, it will configure the IR blaster as part of the Media Center setup.

To learn the new keys:

- hold the remote control from your set top box as close to the IR receiver and learn sensor as possible. If you do not hold your remote control close enough to the learn sensor, you will not get accurate results
- in the Blaster Configuration program, click the **Key Number** you would like to learn (for example: 1)
- then depress and hold the corresponding key on your set top box remote control. You will be instructed in the message box when to

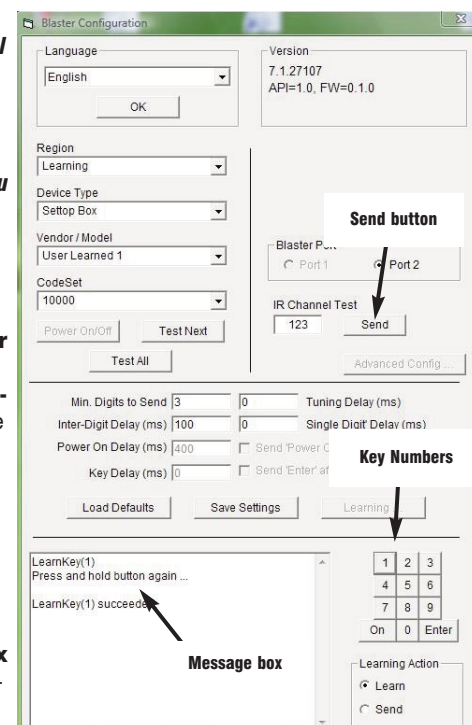

release the key on your remote control.

- **Do this for the keys 0 to 9 plus On and Enter**

You should receive a **LearnKey(key#) Succeeded** message. Then move on to the next key.

If you receive a **LearnKey(key#) Failed error**, this means that the key was either held down too long, or not long enough, or that the remote was not held close enough to the IR sensor. Try again.

Once you are finished with the numbers 0 to 9 and On and Enter, you can test the learning by clicking the **Send button** in the Blaster Configuration program. It will send the numbers 123 to your set top box. Your set top box should now be on channel 123.

Close the **Blaster Configuration program** to save the configuration.

### Using the pre-configured list of set top boxes (WinTV-HVR-1600 and WinTV-HVR-1950 only)

Like universal remote controls, the **Hauppauge IR RemoteBlaster** has a list of common set top boxes which it can control. And like universal remote controls, you must test various codes from the list to see which one applies to your specific set top box. Here is how to do this.

1. Run the **BlastCFG** program from **Start / Programs / Hauppauge WinTV**.

**Note: if some of the controls are greyed out, it means the IRRemote Blaster hardware is not found on your WinTV. Make sure the IR RemoteBlaster cable is firmly plugged in.**

2. Select your **Region**. Choose either **Europe** or **North America**. There is a special region for **Hauppauge** if you want to control Hauppauge DEC boxes.
3. Select the **Device** (cable or satellite), then **Vendor/Model** of your set top box.

The **CodeSet** will contain a list of codes which IRRemoteBlaster knows about the selected Vendor. There might be as many as ten codes for the Vendor chosen.

Click the **Power On/Off** button. **You should see the IR transmitter blink after each click of the Power On/Off button.**

If your set top box turns on or off, then this code is the correct one for your set top box. If not, click **Test Next**. Continue to click **Test Next** until your set top box turns on or off, at which time you have found the correct code.

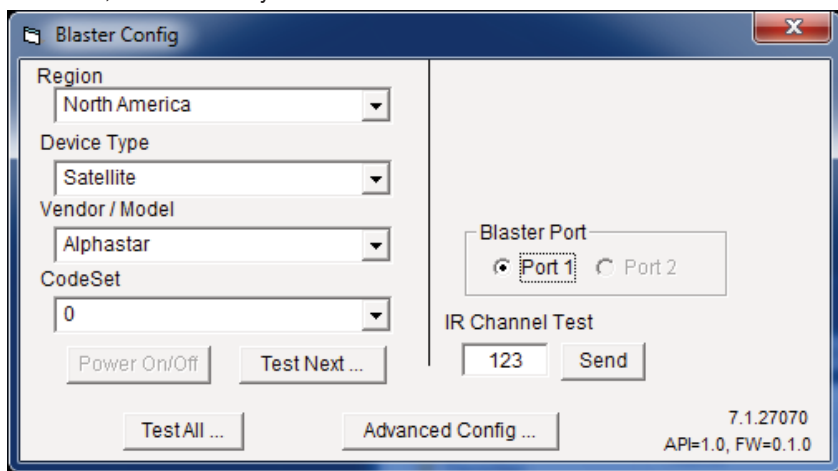

### If you cannot find a code which works with your set top box:

- First make sure the IR transmitter is positioned over the remote sensor on your set top box. Remember, the IR transmitter has a very short distance and needs to be positioned over the remote sensor on your set top box.

- Next, click the **Test All** button. This button will go through all of the codes in our database of set top boxes (over 200 devices at present). After clicking **Test All**, watch your set top box. If it goes on or off, **immediately click Stop Test**. You have found the correct code for your set top box. If your set top box does not turn on or off even after going through all the codes, then either the IR transmitter is not positioned correctly or your box is not supported. See the next section **Learning the remote control codes**.

4. Once you have determined the **Code**, click **Next** to go to the **IR Channel Test** menu. You can click the **Send** button to send a number sequence to your set top box. If your set top box is on, you should see **1 2 3** appear on the channel indicator of your set top box.

## Automatic mapping of your set top box channel numbers to the IR blaster (U.S. only)

You can use our Internet based channel lookup to map your set top box channels automatically. To do this, open the Analog STB Setup menu by clicking the **Configuration menu** (Gear button in the lower left corner of WinTV v7).

Then click on the **Devices tab**. Choose your **WinTV device by clicking on it**, then click **Tuner setup**.

Put a check mark where it says 'Analog TV via set top box' and then click **Next**.



In the **Analog STB Setup** menu, select **Internet Lookup (USA only)**.

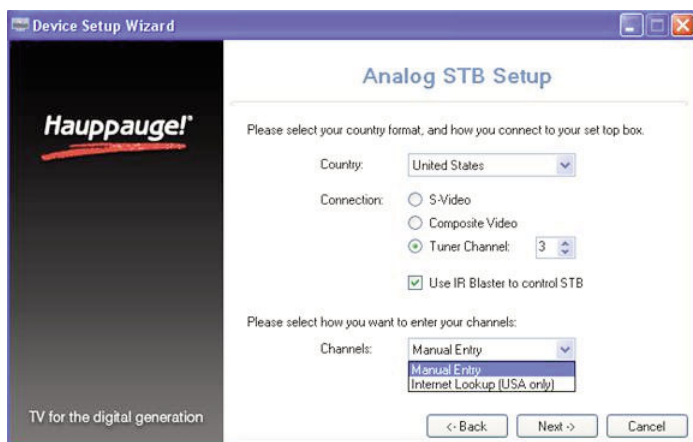

Input your **ZIP code** and press **Next**. The program will list all of the set top box providers for the selected code. Choose your TV provider and click **Next** to populate the channel lineup.



You can then go through and remove any channels if necessary. To remove a channel, click once on the channel, then **click your Right mouse button** and click **Delete**.

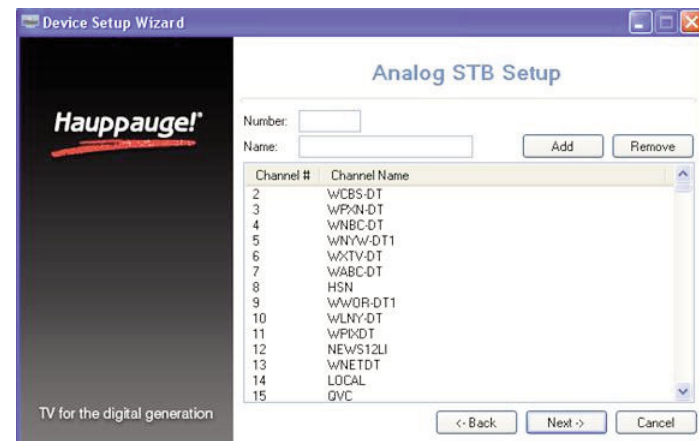

Click **Next** and then **Next** again to finish the IR blaster STB setup.